

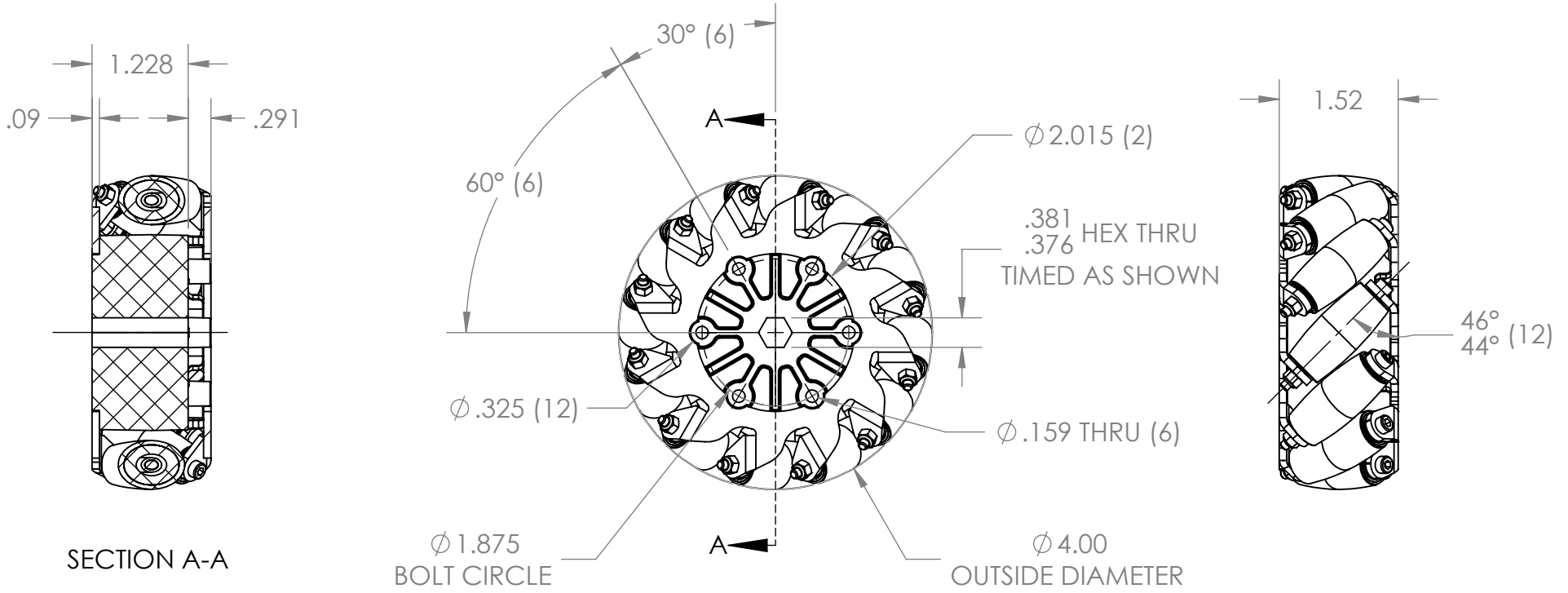

REVISION HISTORY			
REV.	DESCRIPTION	DATE	DRAWN BY
1	ORIGINAL PRINT	7/27/2022	P. YEUNG



SECTION A-A

*** SEE CAD FOR ADDITIONAL TOOLPATH INFO***



UNLESS OTHERWISE SPECIFIED:		COMMENTS:				
DIMENSIONS ARE IN INCHES		DUAL DIMENSIONS ARE IN MILLIMETERS.				
TOLERANCES:		BREAK ALL SHARP EDGES.		TITLE:		
FRACTIONAL	±1/16			4IN BALL BEARING		
ANGULAR: MACH	±1°			MECANUM WHEEL		
ANGULAR: BEND	±5°			375IN HEX BORE RIGHT		
ONE PLACE DECIMAL	±0.1			SIZE	DWG. NO.	REV
TWO PLACE DECIMAL	±0.01			A	am-4735R	1
THREE PLACE DECIMAL	±0.005			SCALE: 1:2		
FOUR PLACE DECIMAL	±0.0005			SHEET 1 OF 1		
MATERIAL	VARIOUS	CHECKED	NAME	DATE		
FINISH		ENG APPR.	NL	7/29/22		
DO NOT SCALE DRAWING		MFG APPR.				
		Q.A.				